

Instructions for use

Stylex / Sirocco / Amfora / Vienna

6200 4010 / 6200 4015, 6200 4011 / 6200 4016, 6200 4050 / 6200 4055, 6200 5005 /
 6200 5010, 6300 4030 / 6300 4035, 6300 4040 / 6300 4045 (Amfora)
 6500 4021 / 6500 4026, 6500 4020 / 6500 4025, 6500 5015 / 6500 5020, 6500 4060 /
 6500 4065, 6500 4070 / 6500 4075 (Vienna)
 6100 2400, 6100 2401, 6100 2402, 6100 2403 (Sirocco)
 6100 3070 (Stylex)

Shower stretcher / Dressing table



6200 4010 / 6200 4015 Amfora
Shower stretcher Hydraulic



6200 4011 / 6200 4016 Amfora
Shower stretcher Electric



6200 4050 / 6200 4055 Amfora
Shower stretcher with drip tray mobile



6300 4030 / 6300 4035 Amfora
Shower stretcher wall mounted



6300 4040 / 6300 4045 Amfora
Shower stretcher with drip tray wall
mounted



6200 5005 / 6200 5010 Amfora
Shower stretcher wall mounted high
/ low



6500 4021 / 6500 4026 Vienna
Dressing table Electric



6500 4020 / 6500 4025 Vienna
Dressing table Hydraulic



6500 4060 / 6500 4065 Vienna
Dressing table mobile



6500 4070 / 6500 4075 Vienna
Dressing table wall mounted



6500 5015 / 6500 5020 Vienna
Dressing table wall mounted high / low



6100 2400 / 6100 2401 / 6100 2402 /
6100 2403 Sirocco Shower stretcher



6100 3070 Stylex Shower stretcher
Stainless Steel

Important:

Read these instructions carefully before using the Shower stretcher / Dressing table!

Date first used





User

Name

Address

Manufacturer

Lopital Nederland B.V.
 Laarakkerweg 9
 5061 JR The Netherlands
 T (0031) 13 52 39 300
 F (0031) 13 52 39 301
 www.lopital.com
 info@lopital.nl

Notes on symbols	
	Read the user instructions before use.
	Direct current 24V DC.
	Note.
	Applied parts.
	Class 2 EMC.

Contents

1.	Introduction.....	33
1.1.	Introduction.....	33
1.2.	Safety.....	34
1.3.	Warranty.....	36
2.	Use.....	37
2.1.	First use.....	37
2.2.	Working with the shower stretcher / dressing table.....	39
3.	Operation.....	40
3.1.	Wheel blocking (only on mobile variant).....	40
3.2.	Side bars.....	40
3.3.	Moving upwards / downwards.....	41
3.4.	Water drainage (only for Stylex, Sirocco and Amfora with drip tray).....	42
3.5.	Changing batteries (only relates to electrical adjustable versions).....	42
3.6.	Charging batteries (only relates to electrical adjustable versions).....	43
4.	Safety functions.....	44
4.1.	Emergency stop button (only relates to electrical adjustable versions).....	44
4.2.	Emergency lowering button (only relates to electrical adjustable versions).....	44
5.	Cleaning and maintenance.....	45
6.	Storage and transport.....	46
7.	Removal of parts.....	47
8.	Technical Specifications.....	47
8.1.	Structure.....	47
8.2.	Drive.....	48
8.3.	Dimensions.....	49
9.	Checklist for technical problems.....	52
10.	Relationship with other supports.....	53
11.	Electromagnetic compatibility.....	54

1. Introduction

1.1. Introduction

The shower stretcher / dressing table is a medical device for caring for and washing less able persons in an ergonomically responsible manner. Comfort is the primary consideration for both the less able person and the carer.

Lopital supplies various versions of its shower stretchers and dressing tables. The range includes stretchers / dressing tables that are secured to a wall, mobile shower stretchers / dressing tables and shower stretchers / dressing tables that are non-mobile. The height of some variants is electrically or hydraulically adjustable.

The shower stretcher / dressing table is multi-functional in use and corresponds to the use of other devices such as beds, wheelchairs and shower chairs, hoisting equipment and sliders such as the EasySlide. These are the essential functions of a shower stretcher / dressing table.

The average technical life of the shower stretcher / dressing table is 10 years, assuming it is cleaned daily and regularly maintained according to the maintenance schedule supplied (*See: Chapter 5 Cleaning and Maintenance*).

The shower stretcher / dressing table is a class 1 product with CE-marking. This marking corresponds with directive 93/42/EC and the revised directive 2007/47/EC for medical devices of 21 March 2010. The shower stretcher / dressing table has been tested for electromagnetic radiation according to norm 60601-1-2.

The Amfora is available in the following versions:

- 6200 4010 – Hydraulic high / low, lying surface 160 cm / 63 inch.
- 6200 4015 – Hydraulic high / low, lying surface 190 cm / 74.8 inch.
- 6200 4011 – Electric high / low, lying surface 160 cm / 63 inch.
- 6200 4016 – Electric high / low, lying surface 190 cm / 74.8 inch.
- 6200 4050 – Fixed height, lying surface 160 cm / 63 inch.
- 6200 4055 – Fixed height, lying surface 190 cm / 74.8 inch.
- 6200 5005 – Wall mounted, electric high / low, lying surface 160 cm / 63 inch.
- 6200 5010 – Wall mounted, electric high / low, lying surface 190 cm / 74.8 inch.
- 6300 4030 – Wall mounted, fixed height, no drip tray, lying surface 160 cm / 63 inch.
- 6300 4035 – Wall mounted, fixed height, no drip tray, lying surface 190 cm / 74.8 inch.
- 6300 4040 – Wall mounted, fixed height, lying surface 160 cm / 63 inch.
- 6300 4045 – Wall mounted, fixed height, lying surface 190 cm / 74.8 inch.

The Vienna is available in the following versions:

- 6500 4020 – Hydraulic high / low, lying surface 160 cm / 63 inch.
- 6500 4025 – Hydraulic high / low, lying surface 190 cm / 74.8 inch.
- 6500 4021 – Electric high / low, lying surface 160 cm / 63 inch.
- 6500 4026 – Electric high / low, lying surface 190 cm / 74.8 inch.
- 6500 4060 – Fixed height, lying surface 160 cm / 63 inch.
- 6500 4065 – Fixed height, lying surface 190 cm / 74.8 inch.
- 6500 5015 – Wall mounted, electric high / low, lying surface 160 cm / 63 inch.
- 6500 5020 – Wall mounted, electric high / low, lying surface 190 cm / 74.8 inch.
- 6500 4070 – Wall mounted, fixed height, lying surface 160 cm / 63 inch.
- 6500 4075 – Wall mounted, fixed height, lying surface 190 cm / 74.8 inch.

The Sirocco is available in the following versions:

- 6100 2400 – Wall mounted left and height adjustable
- 6100 2401 – Wall mounted right and height adjustable
- 6100 2402 – Wall mounted left and fixed height
- 6100 2403 – Wall mounted right and fixed height

The Stylex is available in the following versions:

- 6100 3070 – Standard stainless steel

1.2. Safety

A failure to comply with the following safety points and the further definitions in this user manual could lead to hazardous situations. Please read carefully before use.

Use

The following applies to all shower stretchers and dressing tables:

- It is not permitted to load the shower stretcher / dressing table with more weight than 135 kg / 297.6 lbs.
- Only use original parts, supplied by Lopital.
- Use the shower stretcher / dressing table in a clean and tidy working environment.
- Only verifiably authorised personnel is allowed to work with the shower stretcher / dressing table.
- Swimming pool locations are not considered to be 'normal conditions' and will substantially shorten the lifespan of certain components.
- The shower stretcher / dressing table must be used/cleaned using water that is below 43 degrees Celsius (109 degrees Fahrenheit).

The following applies to all mobile shower stretchers and dressing tables:

- Make sure that the shower stretcher / dressing table brake is applied before transferring clients.
- Notify the less able person before moving the shower stretcher / dressing table.
- Only relocate and move the shower stretcher / dressing table in the lower position.
- When moving the shower stretcher / dressing table, do not adjust upwards or downwards.
- Always try to move backwards over obstacles (rather than forwards).
- The shower stretcher / dressing table may not be used to transport loads other than people.

The following applies to all adjustable shower stretchers and dressing tables:

- Be aware of obstacles when moving upwards and downwards.

Electric adjustable:

- The use of components (ladders, cables, actuators, batteries, etc.) that have not been supplied by Lopital may result in increased emissions or decreased immunity of the shower stretcher / dressing table.
- Charge batteries in a well-ventilated, dry space.
- Portable and mobile RF communication equipment can affect medical devices.
- Medical electrical devices involve special EMC precautions and must be used as per the EMC information outlined in the instructions for use.
- The shower stretcher / dressing table must not be used adjacent to or stacked on other products. However, should that be necessitated, it must be checked whether the stretcher functions normally in this configuration too.

Maintenance

- If the charger or cable become damaged, they must be replaced. (For electric adjustable versions)
- The shower stretcher / dressing table must be inspected and serviced at least once a year.
- Servicing and maintenance of the shower stretcher / dressing table may only be carried out by persons authorised by Lopital.
- Constructive components of the shower stretcher / dressing table may only be replaced by suitably authorised Lopital personnel.
- If erroneous use, transport, an accident or improper maintenance leads to deformation of the shower stretcher / dressing table, it may no longer be used and you must contact the supplier.

In the event of breakdowns, you must contact Lopital or your local supplier.
E-mail: service@lopital.nl



The shower stretcher / dressing table must only be operated by persons who have been sufficiently trained and expert personnel who have experience working with the target group.



The shower stretcher / dressing table must be used in a clinical setting.



Making changes to the construction could affect the safety of the shower stretcher / dressing table. This will also lead to Lopital's liability and warranty conditions being invalidated. As a result, the shower stretcher / dressing table will no longer comply with the guidelines for medical devices.

1.3. Warranty

Lopital products are guaranteed for 2 years with respect to construction and / or material faults. In the event of varying warranty terms, the exact period will be indicated on your invoice; this also serves as the warranty itself.

Components that are subject to wear and tear (such as batteries, hand controls and cables) will not fall under warranty unless there are clear construction and / or material faults.

2. Use

2.1. First use

Before you use the shower stretcher / dressing table, you must check to ensure the following components are present. These components can be replaced by authorised individuals in the event of damage. These components are the applied parts of the shower stretcher / dressing table. These components may come into contact with the user(s) while the shower stretcher / dressing table is in use.



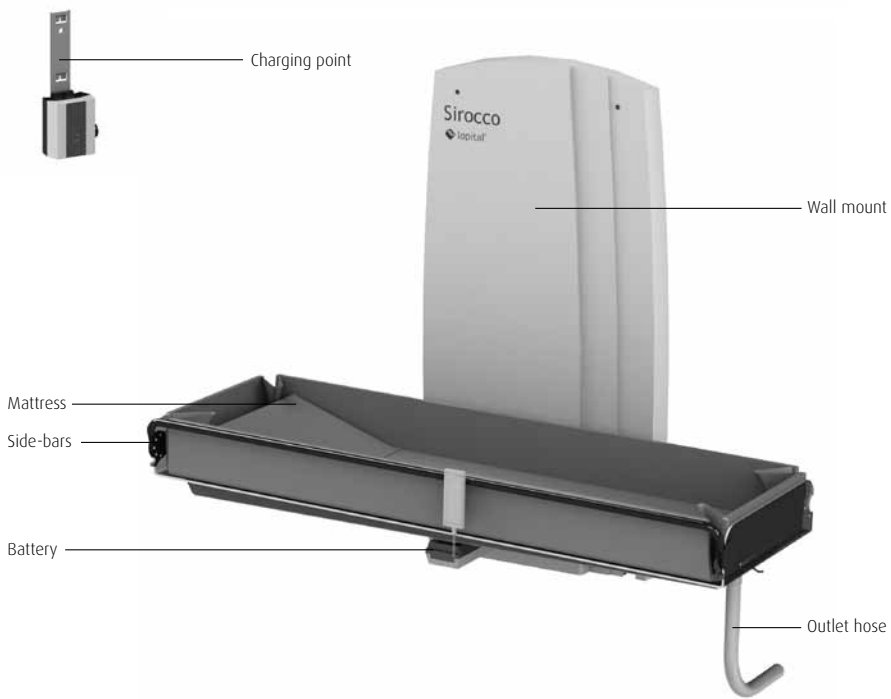

2.2. Working with the shower stretcher / dressing table

Step 1 (only on mobile variants)

Always apply the brake on the shower stretcher / dressing table when transferring patients. (See paragraph 3.1. *wheel blocking*).

Transfer to bed

Step 2

Place the shower stretcher / dressing table alongside the bed with the head-end aligned with the head-side of the less able person.

Step 3

Lower the side bar on the shower stretcher / dressing table (See paragraph 3.2 *Side-bars*).

Step 4 (only on adjustable variants)

Move the bed base on the shower stretcher / dressing table to just above the bed mattress and collapse the side-bars downwards (*on adjustable shower stretchers / dressing tables*).

Step 5

Slide the shower stretcher / dressing table between the head and foot-end so that it protrudes as far as possible over the bed.

Step 6 (only on mobile variants)

Block the wheels on the shower stretcher / dressing table. (See paragraph 3.1. *Wheel blocking*).

Step 7

Go to the other end of the bed and place the EasySlide between the less able person and the shower stretcher / dressing table.

Step 8

Use the EasySlide to slide the person from the bed to the shower stretcher / dressing table.

Step 9 (only on adjustable variants)

Raise the horizontal surface of the shower stretcher / dressing table a few centimetres and close the side-bars.

Step 10 (only on mobile variants)

Take the brake off the shower stretcher / dressing table and remove the easy-slide (See paragraph 3.1. *Wheel blocking*).

3. Operation

3.1. Wheel blocking

(Only on mobile variant)

- The brake can be applied on the shower stretcher / dressing table by pushing the blue lip (1) on the wheel downwards (See figure 1).
- In order to take the shower stretcher / dressing table off the brake, the same lip on the wheel must be moved upwards by tapping the upper side of the lip (2) (See figure 1).

3.2. Side bars

- The shower stretcher / dressing table is equipped with steel, hinged side bars. The side bars are made of stainless steel on the Stylex.
- The side-bar is equipped with safeguards so that the less able person cannot raise the side-bars himself.
- Before the side-bar is collapsed downwards, the safeguard must be unlocked.

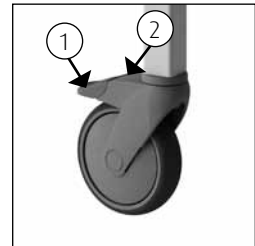

Figure 1: Wheel blocking

- *Wall mounted stretcher / dressing table:* Unlock the safeguard by using one hand to pull the protruding lip / button (1) outwards and raising the side-bar with your other hand. (See Figures 2 and 3).

Mobile stretcher / dressing table: Unlock the safeguard by removing the bolts on both sides of the side bar (1) (See figure 4).

- Turn the unlocked side bar outwards (3).
- Move the side-bar upwards in order to lock it in place again. The side bar is locked on the mobile shower stretcher / dressing table by securing the bolts in the appropriate position. With the wall stretchers / dressing tables, the side bar locks automatically.
- *Siracco:* Make sure that the corner flaps fall inwards so that they do not get jammed in the side-bar locks.

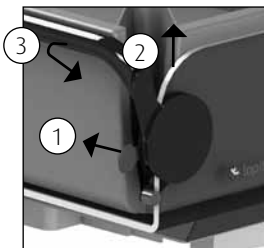

Figure 2: Side bar Siracco

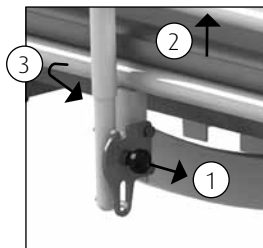

Figure 3: Side bar Amfora / Vienna wall mounted

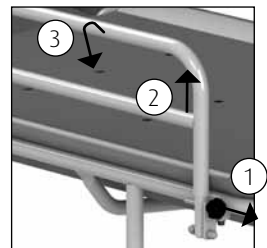

Figure 4: Side bar mobile stretchers / dressing tables

3.3. Moving upwards / downwards

Electric adjustable versions

Moving upwards

- If the less able person is lying on the shower stretcher / dressing table, first put the brake on the wheels (if it is a mobile stretcher / dressing table) and then move the stretcher upwards.
- Move the shower stretcher / dressing table upwards by pressing the button that shows an 'up' arrow. The shower stretcher will then immediately move upwards

(See figure 5).

- You can stop the movement whenever you like by taking your finger off the button.
- During the upward movement, maintain contact with the less able person.
- If the remote control is not being used, it can be hung on the side-bar.
- Ensure that the curly cable on the operating device does not get jammed.

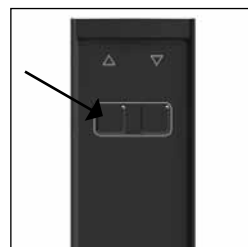

Figure 5: Moving upwards

Moving downwards

- Move the shower stretcher / dressing table downwards by pressing the button that shows a 'down' arrow. The shower stretcher will then immediately move downwards
- (See figure 6).
- You can stop the movement whenever you like by taking your finger off the button.
 - During the downward movement, maintain contact with the less able person.

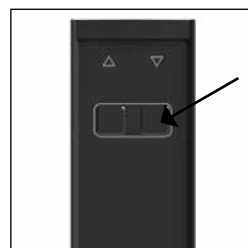

Figure 6: Moving downwards



Before moving the shower stretcher / dressing table upwards, check to ensure there are no persons or objects in the vicinity of the device.

Hydraulic adjustable versions

Moving upwards

- If the less able person is lying on the shower stretcher, first put the brake on the wheels and then move the shower stretcher / dressing table upwards.
- The shower stretcher / dressing table moves gently and evenly upwards as a result of tapping the foot-pedal (See figure 7).
- During use of the pedal, the carer will stand by the long edge of the shower stretcher / dressing table so that the carer cannot twist their upper body away from their feet.
- During the upward movement, maintain contact with the less able person.

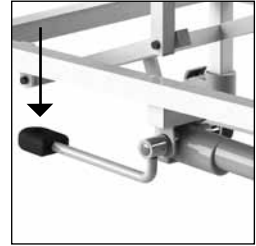

Figure 7: Moving upwards

Moving downwards

- The shower stretcher / dressing table moves downwards as a result of pushing the foot pedal downwards (See figure 8).
- The shower stretcher / dressing table lowers under the influence of gravity. The lowering speed can be modified by keeping the pedal gently depressed.
- During the downward movement, maintain contact with the less able person.

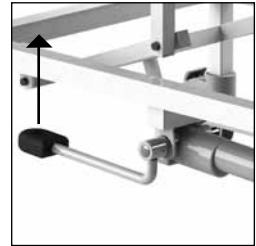

Figure 8: Moving downwards

3.4. Water drainage

(Only for Stylex, Sirocco and Amfora with drip tray)

- Water is drained away from the shower stretcher via a drainage hose.
- Take the hose off the hook and direct it to a drainage point that is as low as possible.
- During transport, always hang the hose on the hook otherwise it may leak and drip.

3.5. Changing batteries

(only relates to electrical adjustable versions)

- If you hear an audible signal, the battery must be changed.
- The battery is housed on the sub-frame of the shower stretcher / dressing table, against the operating electronics. The battery is located under the bed on wall mounted stretchers / dressing tables.

- In order to remove the battery, use one hand to unlock the catch (1) on the battery, then slide the battery to the right (2). (See figure 9).
- To install the fully charged battery, it must first be positioned next to the electronic housing and then clicked into the holder.

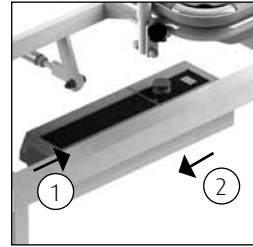

Figure 9: Battery



Make sure that the shower stretcher / dressing table is always ready for use by having a fully charged reserve battery on standby.

3.6. Charging batteries

(only relates to electrical adjustable versions)

- Place the empty battery on the battery charger (See figure 10).
- A green light indicates that the battery charger is switched on. An orange light indicates that the battery must be charged. This light goes off if the battery is full.
- The charged battery can remain on the battery charger without being damaged.
- In order to remove the battery, use one hand to unlock the catch on the battery and the other to support the battery itself.



Figure 10: Battery charger



Only use batteries that are supplied with the shower stretcher / dressing table. Charge batteries that are not used, once every six months to avoid damage. Charging the batteries before they are completely empty will extend their lifespan.

The charger that must be used for the shower stretcher / dressing table is the 'Linak External charger CHJ2'.



Charge batteries in a well-ventilated, dry space.

For instruction videos go to www.lopital.com or www.youtube.com/user/LopitalNL

4. Safety functions

4.1. Emergency stop button

(only relates to electrical adjustable versions)

In the centre of the undercarriage, there is an emergency stop button. Operate this button in an emergency; if the upward or downward movement must be stopped immediately. After the emergency stop has been pressed, all electrical operation will cease to function. Operation may be continued once the situation is stable again. Turn the emergency stop a quarter turn to unlock it again.

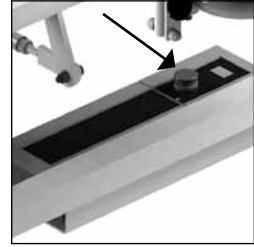

Figure 11: Emergency stop



First check to ensure the hazard has been removed or the problem resolved, before resetting the emergency stop.

4.2. Emergency lowering button

(only relates to electrical adjustable versions)

If the controls stop working and the shower stretcher / dressing table is in a raised position, it can be lowered using the emergency lowering button. This button is located to the left of the emergency stop button (See figure 12).

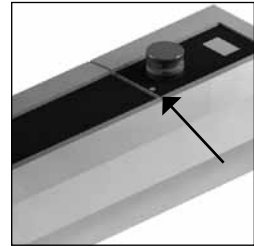

Figure 12: Emergency lowering button

First check to ensure that the emergency button has not been pressed!

- Remove the plug from the manual control.
- Press the emergency lower button (to the left of the emergency stop).

The shower stretcher / dressing table will now return to the lowest position (make sure no persons or objects are under the stretcher).

Take the less able person from the shower stretcher / dressing table and make sure the device is not used until it has been repaired. Place the shower stretcher / dressing table in a safe place and indicate that it is out of order.

Contact the technical service or Lopital's service department.

E-mail: service@lopital.nl

5. Cleaning and maintenance

The shower stretcher / dressing table must be cleaned after every use, with water and regular household cleaning agents. Remove excess soap residues. Do not use any abrasive or other aggressive cleaning products (e.g. chlorine bleach). Practical experience has shown that regular household cleaning agents with limited alcohol content (max. 5%) are most suitable for this purpose. The product Neoquat combi® is recommended for disinfection purposes (on the basis of long-term testing). For the best and most efficient cleaning of the mattress and the bed base, the mattress can be lifted up and removed. Dry the plate on which the mattress lies.

Check the wheels regularly for hairs and dust and remove when necessary. Maintenance and repairs to the shower stretcher / dressing table may only be carried out by authorised personnel.

Maintenance schedule	
After every use	<ul style="list-style-type: none"> • The shower stretcher / dressing table can be cleaned with water and regular household cleaning products.
Daily	<ul style="list-style-type: none"> • Clean and disinfect mattress / harness.
Weekly	<ul style="list-style-type: none"> • Clean frame. • Check wheels for hairs, dust and soap residues and remove if necessary. • Check that the shower stretcher / dressing table is still working correctly.
<p>Annually</p> 	<ul style="list-style-type: none"> • According to the guidelines for medical devices, a shower stretcher / dressing table must be maintained in line with the manufacturer's instructions. This process will preferably be carried out by Lopital or another authorised body. Lopital offers the option of having the shower stretcher / dressing table thoroughly inspected and serviced once a year via Periodic Preventative Maintenance. <p>For more information about the maintenance contract, please contact Lopital (service@lopital.nl) or speak to your supplier.</p>

6. Storage and transport

During transport and storage, the ambient conditions must remain moderate. In other words, the temperature should remain between -40 and +55 degrees Celsius (-40 to 130 degrees Fahrenheit) and humidity levels should be kept as low as possible. Vibration during transport must be kept to a minimum in order to avoid damaging the hinged mechanisms on the stretcher.

7. Removal of parts

All parts that are replaced or removed can be sent back to Lopital BV. You may also offer the parts to the engineer for destruction. We will ensure that all parts are processed in an environmentally-friendly manner.

If you take care of disposal of the product yourself, you must take account of the fact that batteries and chargers must be disposed of as small chemical waste.

8. Technical Specifications



This shower stretcher / dressing table belongs to category 'BF'.



This shower stretcher / dressing table is a class 2 EMC product

The shower stretcher / dressing table is splash-proof; this means that it can be used under the shower. This is indicated with instruction IPX4.

8.1. Structure

Amfora & Vienna mobile:

Subframe	steel + 2-layer powder coating
Upper frame	steel + 2-layer powder coating
Side bars	steel + 2-layer powder coating
Hinges	stainless steel + 2-layer powder coating

Stylex:

Subframe	stainless steel + 2-layer powder coating
Upper frame	stainless steel + 2-layer powder coating
Side bars	stainless steel + 2-layer powder coating
Hinges	stainless steel + 2-layer powder coating

Wall mounted stretcher / dressing table:

Frame	steel + 2-layer powder coating
Side bars	steel + 2-layer powder coating
Hinges	stainless steel + 2-layer powder coating

Mobile stretcher / dressing table:

Wheels Ø 12.5 cm / 4.9 inch, double blocking
Attachment equipment stainless steel + galvanised steel

Weight

Amfora

6200 4010/15	57 / 60 kg	125.7 / 132.3 lbs
6200 4011/16	60 / 60 kg	132.3 / 132.3 lbs
6200 4050/55	34 / 37 kg	75 / 81.6 lbs
6200 5005/10	85 / 85 kg	187.4 / 187.4 lbs
6300 4030/35	18 / 18 kg	39.7 / 39.7 lbs
6300 4040/45	20 / 20 kg	44.1 / 44.1 lbs

Vienna

6500 4020/25	53 / 56 kg	116.9 / 123.5 lbs
6500 4021/26	57 / 60 kg	125.7 / 132.3 lbs
6500 4060/65	35 / 37 kg	77.2 / 81.6 lbs
6500 5015/20	75 / 75 kg	44.1 / 44.1 lbs
6500 4070/75	23 / 23 kg	50.7 / 50.7 lbs

Sirocco

6100 2400	80 kg	176.4 lbs
6100 2401	80 kg	176.4 lbs
6100 2402	40 kg	88.2 lbs
6100 2403	40 kg	88.2 lbs

Stylex

6100 3070	50 kg	110.2 lbs
-----------	-------	-----------

Maximum load

135 kg / 297.6 lbs

8.2. Drive

(Electric variants)

High-low drive	Actuator 24 V DC
Control box	24 VDC, max. 250W
Battery	24 V, max. 250 W
Battery charger	230 V AC, connection value 100 W, wall-mounted

8.3. Dimensions

External dimensions

Amfora (l x w x h)

6200 4010/15	160 / 190 x 74 x 70 to 110 cm	63 / 74.8 x 29.1 x 27.6 to 43.3 inch
6200 4011/16	160 / 190 x 74 x 75 to 115 cm	63 / 74.8 x 29.1 x 29.5 to 45.3 inch
6200 4050/55	160 / 190 x 74 x 103 cm	63 / 74.8 x 29.1 x 40.6 inch
6200 5005/10	160 / 190 x 93 x 43 to 103 cm	63 / 74.8 x 36.6 x 16.9 to 40.6 inch
6300 4030/35	160 / 190 x 85 x 108 cm	63 / 74.8 x 36.6 x 42.5 inch
6300 4040/45	160 / 190 x 85 x 108 cm	63 / 74.8 x 36.6 x 42.5 inch

Vienna (l x w x h)

6500 4020/25	160 / 190 x 74 x 68 to 108 cm	63 / 74.8 x 29.1 x 26.8 to 42.5 inch
6500 4021/26	160 / 190 x 74 x 71 to 115 cm	63 / 74.8 x 29.1 x 28 to 45.3 inch
6500 4060/65	160 / 190 x 74 x 68 to 108 cm	63 / 74.8 x 29.1 x 26.8 to 42.5 inch
6500 5015/20	160 / 190 x 85 x 43 to 103 cm	63 / 74.8 x 33.5 x 16.9 to 40.6 inch
6500 4070/75	160 / 190 x 85 x 110 cm	63 / 74.8 x 33.5 x 43.3 inch

Sirocco (l x w x h)

6100 2400	200 x 81 x 43 to 103 cm	78.7 x 31.9 x 16.9 to 40.6 inch
6100 2401	200 x 81 x 43 to 103 cm	78.7 x 31.9 x 16.9 to 40.6 inch
6100 2402	200 x 81 cm	78.7 x 31.9 inch
6100 2403	200 x 81 cm	78.7 x 31.9 inch

Stylex (l x w x h)

6100 3070	– 194 x 72,5 x 75 tot 118 cm	764 x 28.3 x 29.5 tot 46.5 inch
-----------	------------------------------	---------------------------------

Water drainage hose	Internal Ø 4 cm / 1.6 inch
Wheel base	120 cm / 47.2 inch
Track width	65 cm / 25.6 inch

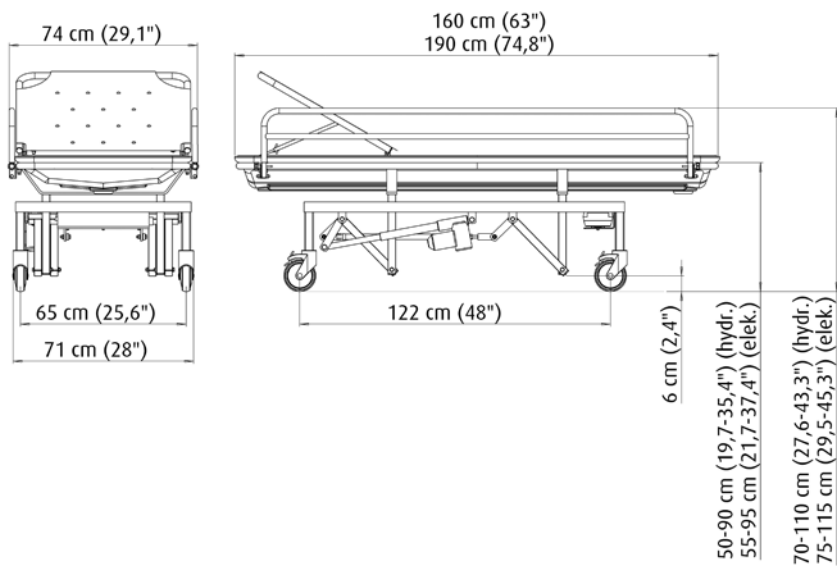
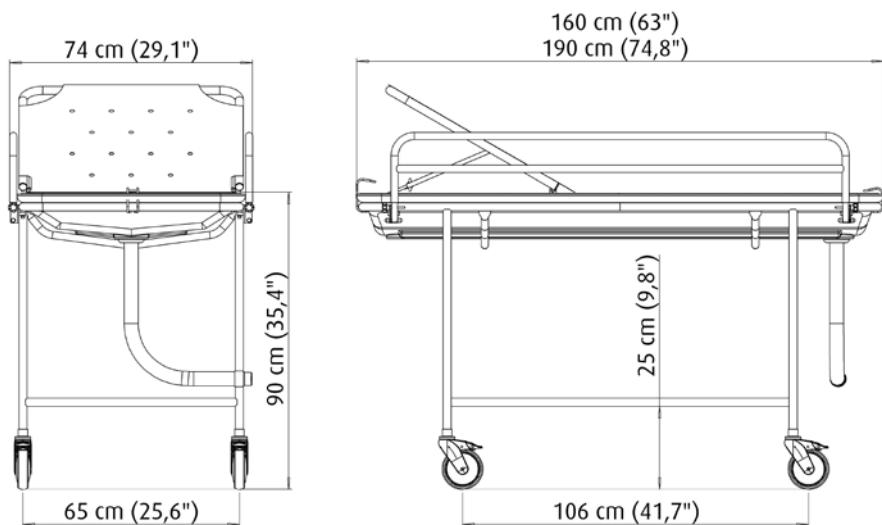

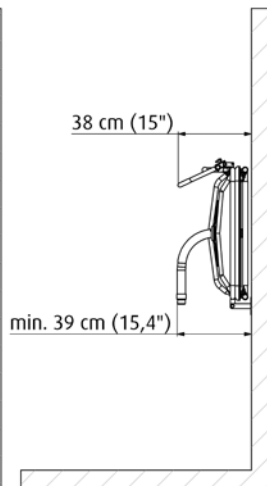
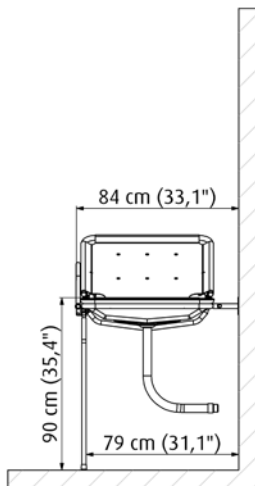
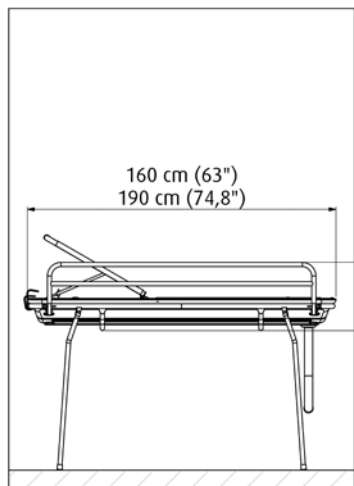
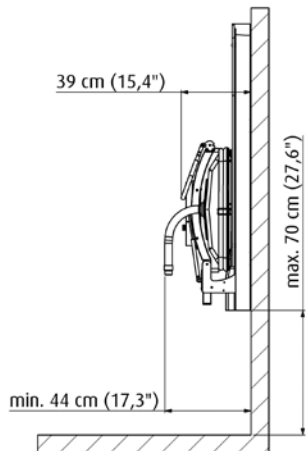
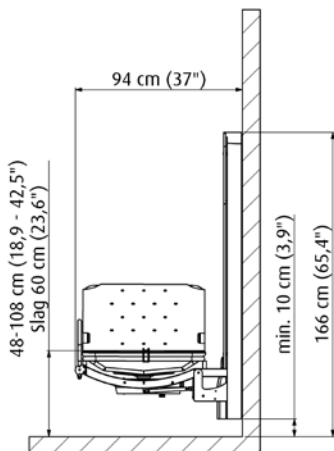
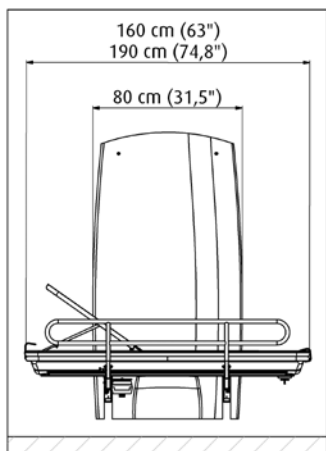

9. Checklist for technical problems

Problem	Cause	Solution
Shower stretcher / dressing table is hard to move	Dirt and soap between wheels	Clean wheels
Shower stretcher / dressing table does not move upwards or downwards	Connection between pump and pedal has become disconnected	Tighten screws on connector Contact Lopital Nederland B.V.
	Pump leaking or broken	Turn emergency button 90 degrees to the right
	Emergency stop button used	Charge battery / install reserve battery
	Battery empty	Check plugs (to side of control box)
	Plugs removed	Check plugs Contact Lopital Nederland B.V.
	Manual controls not working	
Light on the charger does not come on	Charger is not plugged in	Connect charger
	Charger is not working	Contact Lopital Nederland B.V.
Shower stretcher dressing table stops	Emergency stop button used	Turn emergency button 90 degrees to the right
	Technical issue	Contact Lopital Nederland B.V.

For all other issues please contact Lopital Nederland B.V.
Telephone: +31 (0)13 - 5239300
Fax: +31 (0)13 - 5239301
E-mail: service@lopital.nl

10. Relationship with other supports

EasySlide

The EasySlide is the ideal device for transferring from bed to shower stretcher / dressing table and vice versa. The physical burden and time required when using the EasySlide is minimal. The EasySlide is suitable for most bed and chair transfers from and to the shower stretcher / dressing table.

Hoist

The adjustable shower stretchers / changing tables are between 50 cm / 19.7 inches in height (hydraulic) and 55 cm / 21.7 inches (electrical) with an underneath docking of 6 cm / 2.4 inches. The non-adjustable shower stretchers / changing tables are 90 cm / 35.4 inch in height. The underneath docking of the fixed stretcher / changing table is 25 cm / 9.8 inches.

Wheelchair

In lower settings of 48-55 cm / 18.9-21.7 inch, patients can be transferred from the adjustable shower stretcher / dressing table to wheelchair and vice versa. An ideal device to be used during this operation is the small EasySlide (and possibly a sliding board).

Bed

The shower stretcher / dressing table is primarily used to wash users while they are lying down. Users can be moved, using the EasySlide, from any (high or low) bed to the shower stretcher / dressing table in a lying position. The shower stretcher / dressing table must be brought to the same height as the bed to carry out this process.

11. Electromagnetic compatibility

(For electric variants)

Guidance and Manufacturer's declaration-electromagnetic emissions		
The shower stretcher / dressing table is intended for use in the electromagnetic environment specified below. The customer or the user of the shower stretcher / dressing table should assure that it is used in the following environment:		
Emissions Test	Compliance	Electromagnetic Environment - guidance
RF emissions CISPR11	Group 1	The shower stretcher / dressing table uses RF energy only for its internal function. Therefore, its RF emissions are very low and are not likely to cause any interference in nearby electronic equipment.
RF emissions CISPR11	Class B	The shower stretcher / dressing table is suitable for use in all establishments, including domestic establishments and those directly connected to the public low-voltage power supply network that supplies buildings used for domestic purposes.
Harmonic emissions IEC 61000-3-2	Class A	
Voltage Fluctuations/ Flicker emissions IEC 61000-3-3	Complies	

Guidance and Manufacturer's declaration-electromagnetic immunity			
The shower stretcher / dressing table is intended for use in the electromagnetic environment specified below. The customer or the user of the shower stretcher / dressing table should assure that it is used in the following environment:			
Immunity Test	IEC 60601-1-2 Test Level	Compliance Level	Electromagnetic Environment - guidance
Electrostatic discharge (ESD) IEC 61000-4-2	±6 kV contact ±8 kV air	±6 kV contact ±8 kV air	Floors should be made of wood, concrete, or ceramic tile. If floors are covered with synthetic material, the relative humidity should be at least 30%.
Electrical fast transient/burst IEC 61000-4-4	±2 kV for power supply lines	±2 kV for power supply lines	Mains power quality should be that of a typical commercial or hospital environment.
Surge IEC 61000-4-5	±1 kV line(s) to line(s) ±2 kV line to earth	±1 kV line(s) to line(s) ±2 kV line to earth	Mains power quality should be that of a typical commercial or hospital environment.
Voltage dips, short interruptions, and voltage variations on power supply input lines IEC 61000-4-11	<5% Un (>95% drop in Un) for 0,5 cycle 40% Un (60% drop in Un) for 5 cycles 70% Un (30% drop in Un) for 25 cycles <5% Un (>95% drop in Un) for 5 seconds	<5% Un (>95% drop in Un) for 0.5 cycle 40% Un (60% drop in Un) for 5 cycles 70% Un (30% drop in Un) for 25 cycles <5% Un (>95% drop in Un) for 5 seconds	Mains power quality should be that of a typical commercial or hospital environment. The shower stretcher / dressing table is equipped with a battery.
Power frequency (50/60 Hz) magnetic field IEC 61000-4-8	3 A/m	3 A/m	Power frequency magnetic fields should be at levels characteristic of a typical location in a typical commercial or hospital environment.
NOTE Un is the a.c. mains voltage prior to application of the test level			

Guidance and Manufacturer's declaration-electromagnetic immunity			
The shower stretcher / dressing table is intended for use in the electromagnetic environment specified below. The customer or the user of the shower stretcher / dressing table should assure that it is used in the following environment:			
Immunity Test	IEC 60601-1-2 Test Level	Compliance Level	Electromagnetic Environment - guidance
RF Common mode/ Conducted Susceptibility IEC 61000-4-6 Radiated RF Electromag- netic Field IEC 61000-4-3	3 Vrms 150 kHz to 80 MHz 3 V/m 80 MHz to 2,5 GHz	3 V 3 V/m	Portable and mobile RF communications equipment should be used no closer to any part of the shower stretcher / dressing table, including cables than the recommended separation distance calculated from the equation applicable to the frequency of the transmitter. Recommended separation distance $d = 1,2 \sqrt{P}$ $d = 1,2 \sqrt{P}$ 80 MHz to 800 MHz $d = 2,4 \sqrt{P}$ 800 MHz to 2,5 GHz Where P is the maximum output power rating of the transmitter in watts (W) according to the transmitter manufacturer and d is the recommended separation distance in meters (m). Field strengths from fixed RF transmitters, as determined by an electromagnetic site survey, ^a should be less than the compliance level in each frequency range. ^b Interference may occur in the vicinity of equipment marked with the following symbol: 
NOTE 1 At 80 MHz and 800 MHz, the higher frequency range applies. NOTE 2 These guidelines may not apply in all situations. Electromagnetic propagation is affected by absorption and reflection from structures, objects and people.			
a Field strengths from fixed transmitters, such as base stations for radio (cellular/cordless) telephones and land mobile radios, amateur radio, AM and FM radio broadcast and TV broadcast cannot be predicted theoretically with accuracy. To assess the electromagnetic environment due to fixed RF transmitters, an electromagnetic site survey should be considered. If the measured field strength in the location in which the shower stretcher / dressing table is used exceeds the applicable RF compliance level above, the shower stretcher / dressing table should be observed to verify normal operation. If abnormal performance is observed, additional measures may be necessary, such as re-orienting or relocating the shower stretcher / dressing table. b Over the frequency range 150 kHz to 80 MHz, field strengths should be less than 3 V/m.			

Recommended separation distance between portable and mobile RF communications equipment and the shower stretcher / dressing table			
The shower stretcher / dressing table is intended for use in the electromagnetic environment in which radiated RF disturbances are controlled. The customer or the user of the shower stretcher / dressing table can help prevent electromagnetic interference by maintaining a minimum distance between portable and mobile RF communications equipment (transmitters) and the shower stretcher / dressing table as recommended below, according to the maximum output power of the communications equipment.			
Rated maximum output power of transmitter W	Separation distance according to frequency of transmitter m		
	150 kHz to 80 MHz $d = 1,2 \sqrt{P}$	80 MHz to 800 MHz $d = 1,2 \sqrt{P}$	800 MHz to 2,5 GHz $d = 2,4 \sqrt{P}$
0,01	0,12	0,12	0,24
0,1	0,38	0,38	0,76
1	1,2	1,2	2,4
10	3,8	3,8	7,6
100	12	12	24
For transmitters rated at a maximum output power not listed above, the recommended separation distance d in meters (m) can be estimated using the equation applicable to the frequency of the transmitter, where P is the maximum output power rating of the transmitter in watt (W) according to the transmitter manufacturer.			
NOTE 1 At 80 MHz and 800 MHz, the separation distance for the higher frequency range applies.			
NOTE 2 These guidelines may not apply in all situations. Electromagnetic propagation is affected by absorption and reflection from structures, objects and people.			